

CHILLROW

Row Based Cooling Precision Air Conditioner
Cooling capacity:24.2kW~65.3kW

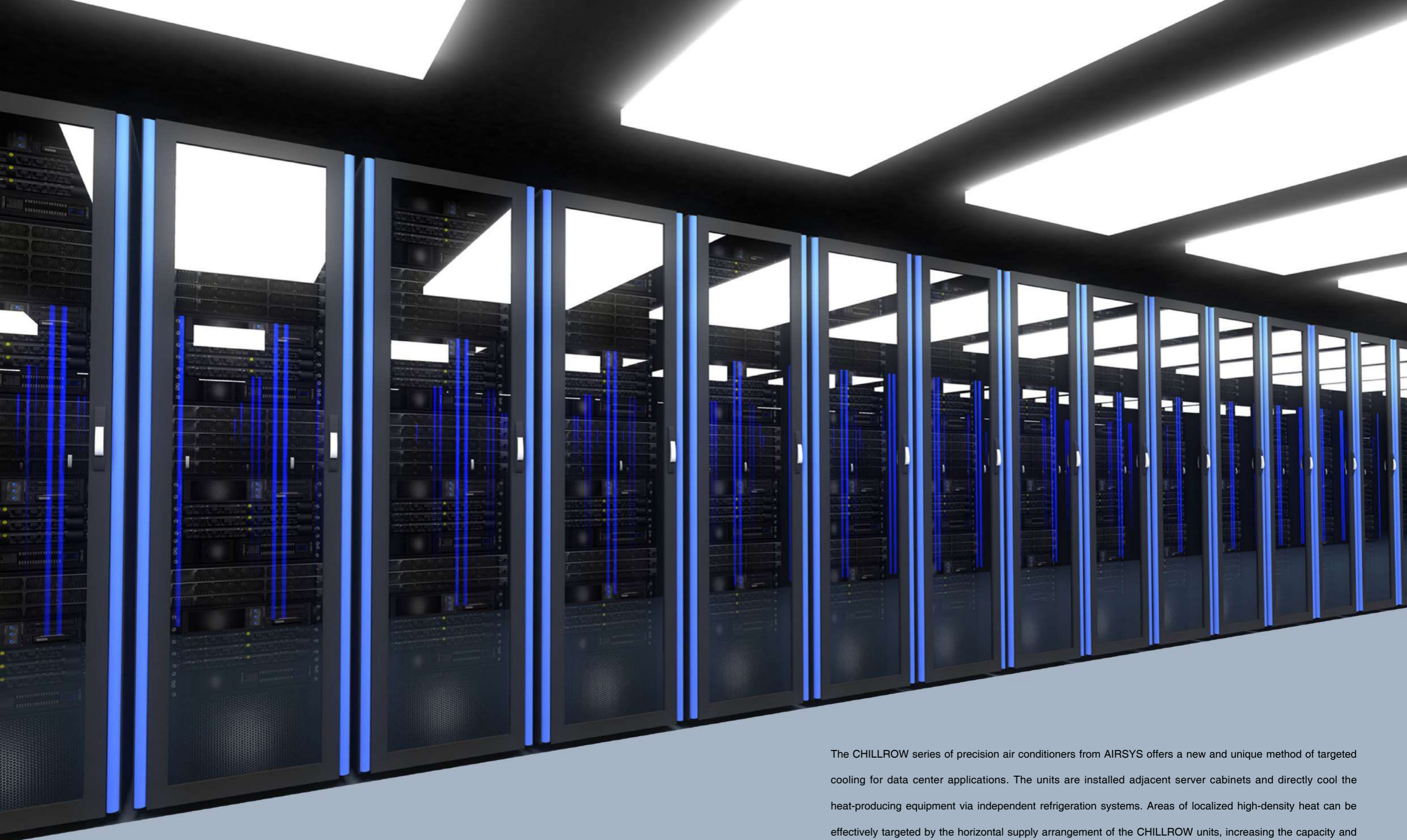

The CHILLROW series of precision air conditioners from AIRSYS offers a new and unique method of targeted cooling for data center applications. The units are installed adjacent server cabinets and directly cool the heat-producing equipment via independent refrigeration systems. Areas of localized high-density heat can be effectively targeted by the horizontal supply arrangement of the CHILLROW units, increasing the capacity and efficiency of the overall cooling systems.

Unit Identification

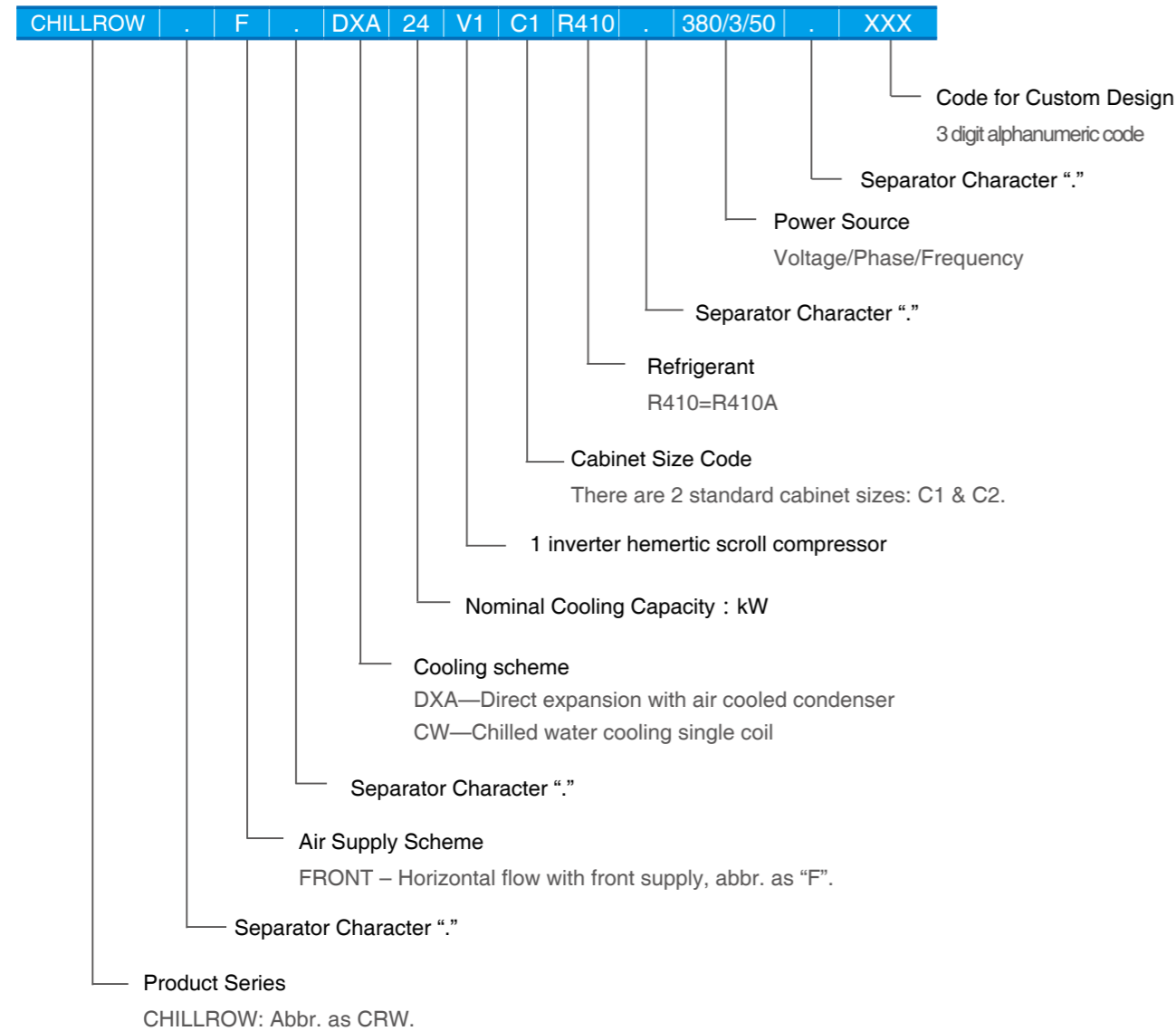

Operating Range & Control Accuracy

CHILLROW.DXA

Operation Range

Ambient Temperature:

- 15°C to + 45°C; operational range can be expanded to as low as -40°C when equipped with low-ambient enhancement option

Refrigeration pipework horizontal length limits:

The combined gas and liquid pipe length in the horizontal plane must be no more than 30 meters. (Please consult with the factory or dealer if distance is over this limit.)

Refrigeration pipework vertical height limits:

Outdoor unit above the indoor unit: <=20 meters

Outdoor unit below the indoor unit: <=5 meters

(Please consult with the factory or dealer if heights are outside these limits.)

Control Precision

Temperature range: 15°C~45°C; Precision: ±1°C;

Relative humidity range: 35%~80%; Precision: ±5%.

CHILLROW.CW

Operating Range

Water pressure specification:

Higher than the system total pressure drop, but lower than 1250kPa

Control Accuracy

Temperature Range and Accuracy:

Range: 15~45°C, Accuracy: ±1°C;

Applications

- Medium to large telecommunication exchanges
- Medium to large data centers and computer rooms
- Museums and libraries
- Precision machine shops

System Schematic & Operation

CHILLROW.DXA

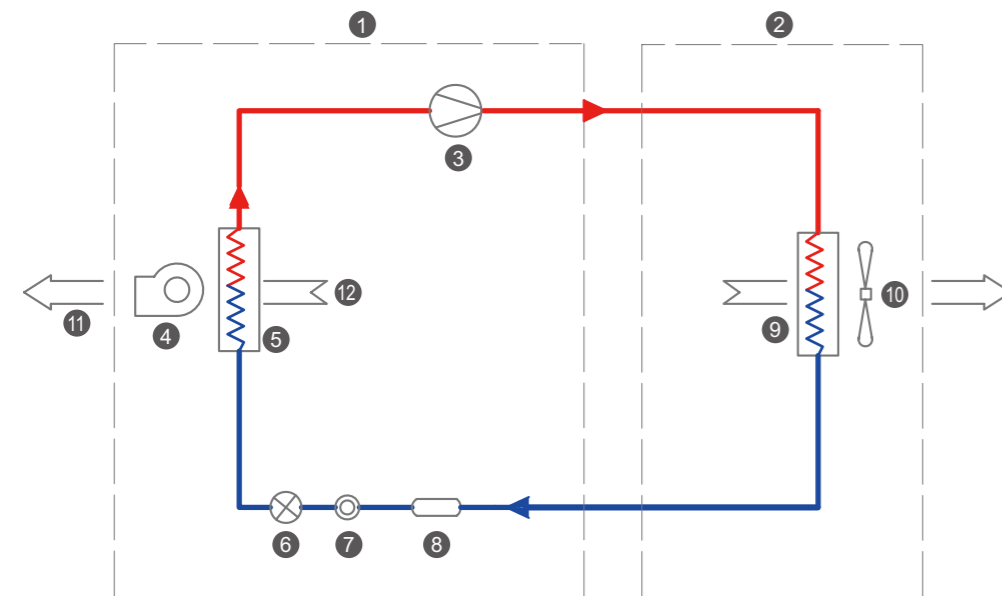

- 1 Indoor
- 2 Outdoor
- 3 Compressor
- 4 Indoor Fan
- 5 Evaporator
- 6 Expansion Valve
- 7 Sight Glass
- 8 Filter Dryer
- 9 Condenser
- 10 Outdoor Fan
- 11 Supply Air
- 12 Return Air

CHILLROW.CW

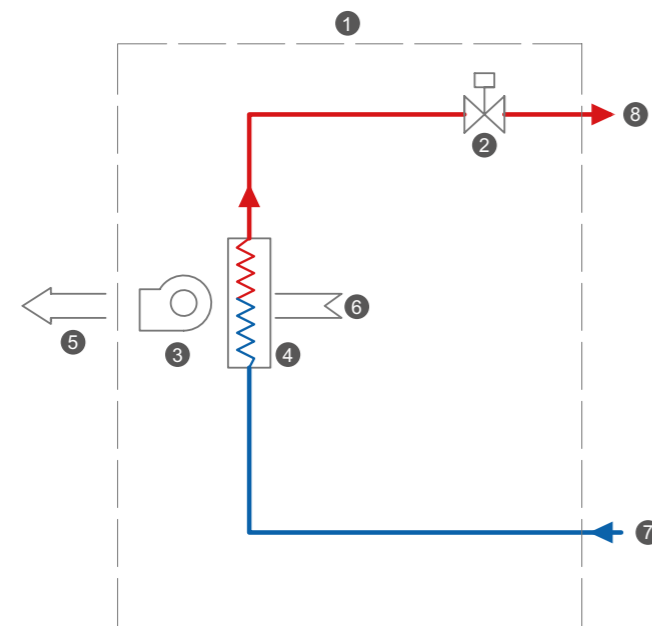

- 1. Indoor
- 2. Electric valve
- 3. Supply fan
- 4. Evaporator
- 5. Supply air
- 6. Return air
- 7. Water in
- 8. Water out

Advantages

High Level of Flexibility

The small dimensions and horizontal supply air arrangement allow for a large amount of flexibility in placement of the CHILLROW units.

They are suitable for both new and existing data centers, can be located on a standard or raised floor, and are highly scalable to easily meet demand as cooling demand grows.

Reduced Running Cost

When CHILLROW units are installed between server cabinets, directly adjacent the heat producing equipment, they can effectively minimize the mixture of hot and cold air, thereby potentially increasing the cooling effectiveness by 30% to 45% when compared with traditional cooling systems.

Product Features

Eco-friendly Refrigerant

R410A is used in DXA units and has an Ozone Depletion Potential (ODP) of 0.

Convenient Maintenance

Service access is via both the front and rear of the units, allowing routine maintenance to occur in location, without affecting the operation of the surrounding equipment or other operational precision coolers. The CRW.F.CW25R1 unit even has 5 hot-swappable fans which can be independently controlled.

Convenient Installation

CHILLROW units have four composite castors, for increased maneuverability in tight spaces, and height adjustable fixed legs, for stability and support once in place. As well as this, pipe connections are able to be made to either the top or bottom of the unit, according to the installation requirements.

Consistent Appearance

CHILLROW units are available in two industry-standard widths (300mm and 600mm), and are designed to match typical server cabinets in both dimensions and color.

Supply Air Arrangement

The short horizontal air path through the units, with both front supply and lateral supply available and rear return, reduces the required fan power and therefore the overall efficiency.

Heat Rejection Options

The CHILLROW precision coolers are available in both DXA (refrigerated) and CW (chilled water) heat rejection options. DXA units eliminate the risk of water leakage and can provide some level of redundancy, while CW units are viable where a new or existing chilled water system is available. The heat rejection configuration can be selected to best meet the needs of each particular installation.

Remote Control & Monitoring Network

Networking and Monitoring of air conditioning equipment is typically a subsystem of a Building Management System (BMS) and provides centralized monitoring and management of all the air-conditioning equipment.

Thanks to years of experience in the production and application of precision air conditioning equipment, AIRSYS is able to provide a variety of monitoring systems ranging from simple SMS alarm monitoring to the most sophisticated tERA cloud based GPRS wireless centralized monitoring system. There is a solution available to suit all sites and installations.

A given unit can be remote controlled or monitored via several means:

- 3 kinds of local direct cable connection
- 3 kinds of LAN network connection
- 4 kinds of wireless network connection

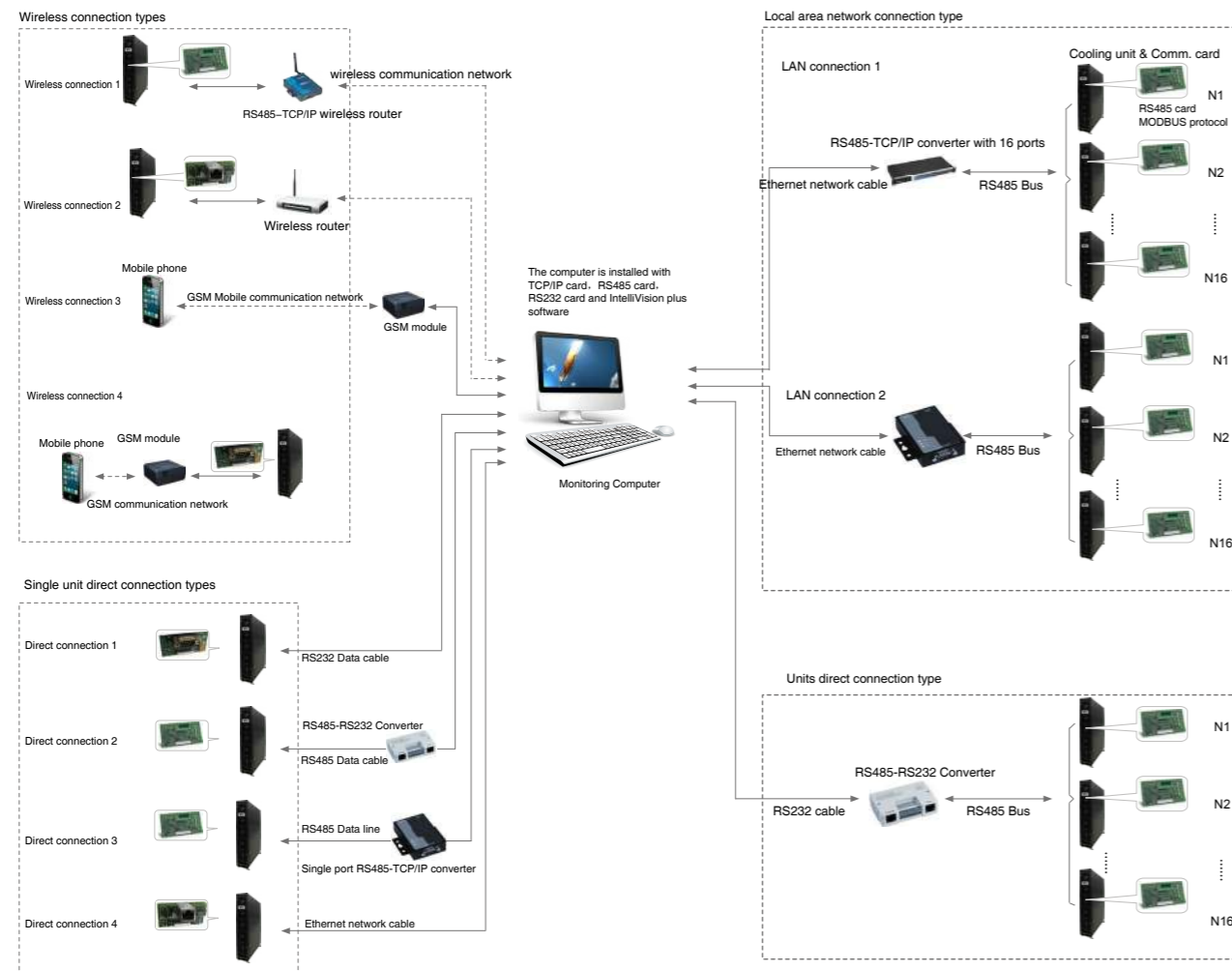

Product Configuration

Standard Configuration

Standard Configuration	DXA	CW
Powder painted steel frame	●	●
Powder painted steel panel with inside thermal and acoustic insulation	●	●
AC powered EC centrifugal fan	●	●
Compressor inverter	●	—
Hermetic DC inverter scroll compressor	●	—
Copper tube aluminum fin coil	●	●
Electronic expansion valve	●	—
Sight glass	●	—
Dry filter	●	—
High pressure transducer	●	—
Pressure switch for high/low pressure protection	●	—
Condensing water tray	●	●
Washable G4 air filter	●	●
Motorized 2-way valve	—	●
Temperature sensor at supply air inlet	●	●
Temperature sensor at return air inlet	●	●
Installation support stand with adjustable legs	●	●
Composite castor	●	●
Colored touch screen graphical user interface	●	●
Microprocessor control	●	●
RS485 Communication	●	●
Clock function	●	●
Phase sequence protection for power supply	●	●
Electrical control panel	●	●
Condenser fan speed controller	●	—
Wooden Package	●	●

Note: "●" Standard configuration, "—" no option available.

Options

Optional Configuration	DXA24V1C1	DXA38V1C2	CW25C1	CW65C2
Air pressure switch for clogged filter alarm.	○	○	○	○
Floor water leakage alarm kit	○	○	○	○
Humidifier	(1)	○	○	○
Electric heater	○	○	○	○
Condensate pump	○	○	○	○
RS485-RS232 converter	○	○	○	○
RS485-TCP/IP converter	○	○	○	○
Motorized 3-way valve	—	—	○	○
Automatic transfer switch (ATS)	—	○	○	○

Note: "○" available option, "—" no option available.

(1) Optional external humidifier

Specification & Parameters

CHILLROW.DXA

Model		DXA24V1C1	DXA38V1
Supply air scheme		F	
Cooling Capacity			
Total(1)	kW	26.8	43.8
Sensible(1)	kW	26.8	43.8
Total(2)	kW	24.2	40.1
Sensible(2)	kW	23.3	38.1
Total(3)	kW	21.6	36.1
Sensible(3)	kW	20.4	34.0
Compressor			
Type		Hermetic DC Inverter Scroll Type	
Max. power input	kW	7.5	13
Max. current input	A	14.7	21.5
Supply fan			
Type		AC Powered EC Centrifugal Fan	
Qty. of fan	n.	6	2
Air volume	m ³ /h	5030	10550
Power	kW	1.27	2.08
Air filter			
		G4	
Electric heater(4)			
Electric heater capacity	kW	2.3	6
Working steps	n.	1	1
Humidifier(4)			
Type		Electrode	
Humidification capacity	kg/h	5 (External)	3
Power	kW	3.7	2.3
Outdoor Condenser			
Model*Qty.(5)		CMEG10V1*1	CMEG15V2*1
Model*Qty.(5)		CMEG15V2*1	CMEG20V2*1
Power supply			
Power source		380V/3Ph/50Hz	
Unit max. operating power (7)	kW	11.1	21.1
Unit max. operating current (7)	A	21.8	33.6
Unit piping connection			
Humidifier water supplyΦ	in	1/2"	1/2"
Condensate water drainageΦ	mm	14	14
Refrigerant discharge lineΦ	mm	16	22
Refrigerant liquid lineΦ	mm	12	16
Unit dimensions and weight			
Width	mm	300	600
Depth	mm	1100	1100
Height	mm	2000	2000
Weight	kg	245	315
Wooden package dimensions and weight			
Width	mm	710	710
Depth	mm	1310	1310
Height	mm	2180	2180
Weight	kg	330	390

(1)Return air dry bulb temperature 40℃, RH 20%, outdoor dry bulb temperature 35℃;

(2)Return air dry bulb temperature 35℃, RH 27%, outdoor dry bulb temperature 35℃;

(3)Return air dry bulb temperature 30℃, RH 35%, outdoor dry bulb temperature 35℃;

(4)Optional;

(5)Select if ambient temperature below 40℃. Detail data please refer to CMEG Technical Parameters;

(6)Select if ambient temperature over 40℃. Detail data please refer to CMEG Technical Parameters;

(7)Maximum operating power and current are calculated at return air dry bulb temperature of 40℃ and RH 20%, outdoor dry bulb temperature of 45℃, with the unit in dehumidification mode and electric heater operating at full load.

CHILLROW.CW

Model		CW25C1	CW65C2
Supply air scheme		F	
Cooling Capacity			
Total(1)	kW	27.7	65.3
Sensible(1)	kW	27.1	64.3
Total(2)	kW	20.6	50.6
Sensible(2)	kW	20.6	50.3
Total(3)	kW	18.7	43.1
Sensible(3)	kW	18.4	43.1
Total(4)	kW	20.3	49.1
Sensible(4)	kW	20.3	47.8
Cooling coil			
Water flow(1)	m ³ /h	4.5	11.5
Water pressure drop (coil and valve)(1)	kPa	68.1	64.1
Water flow(2)	m ³ /h	3.4	12.7
Water pressure drop (coil and valve)(2)	kPa	44	76
Water flow(3)	m ³ /h	3.7	9.3
Water pressure drop (coil and valve)(3)	kPa	49.4	43
Water flow(4)	m ³ /h	3.2	9
Water pressure drop (coil and valve)(4)	kPa	41	41
Supply fan			
Type		AC Powered EC Centrifugal Fan	
Qty.	n.	6	3
Air volume	m ³ /h	5020	12200
Power input	kW	0.75	2.4
Air filter			
		G4	
Electric heater (5)			
Electric heater capacity	kW	2.3	6
Working steps	n.	1	1
Humidifier (5)			
Type		Electrode	
Humidification capacity	kg/h	3	3
Power	kW	2.3	2.3
Power supply			
		230V/1Ph/50Hz	380V/3Ph/50Hz
Unit max. operating power	kW	1.2	3.3
Unit max. operating current	A	10.1	6.3
Unit piping connection			
Condensing waterΦ	mm	14	14
Chilled water outlet/inletΦ	in	1"	1 1/2"
Unit dimensions and weight			
Width	mm	300	600
Depth	mm	1100	1100
Height	mm	2000	2000
Weight	kg	210	280
Wooden package dimensions and weight			
Width	mm	710	710
Depth	mm	1310	1310
Height	mm	2180	2180
Weight	kg	285	355

(1)Return air dry bulb temperature 35℃、RH25%、 water inlet/outlet temperature 10℃/15℃;

(2)Return air dry bulb temperature 40℃、RH20%、 water inlet/outlet temperature 18℃/24℃;

(3)Return air dry bulb temperature 35℃、RH27%、 water inlet/outlet temperature 15℃/21℃;

(4)Return air dry bulb temperature 30℃、RH35%、 water inlet/outlet temperature 10℃/16℃;

(5)Optional.

CMEG系列

Model		CMEG10V1	CMEG15V2	CMEG20V2
Capacity (1)	kW	35.4	47.6	67.4
Fan Qty	No.	1	2	2
Air Flow	m ³ /h	9700	11600	20100
Power Input	kW	0.63	0.74	1.26
Current	A	3.0	3.4	6.0
Connection Size				
Gas Pipe Φ	mm	22	22	28
Liquid Pipe	mm	16	19	19
Unit Dimension				
Width	mm	1340	1540	2400
Depth	mm	620	620	630
Height	mm	1070	1070	1135
Weight	kg	110	130	155
Wooden Packaging Dimension				
Width	mm	1455	1655	2515
Depth	mm	755	755	765
Height	mm	1255	1255	1290
Weight	kg	160	180	205

(1)The capacity is rated at entering air temperature 35°C and condensing temperature 50°C condition.

Unit Dimensions

DXA24V1C1 Unit Dimension Drawing

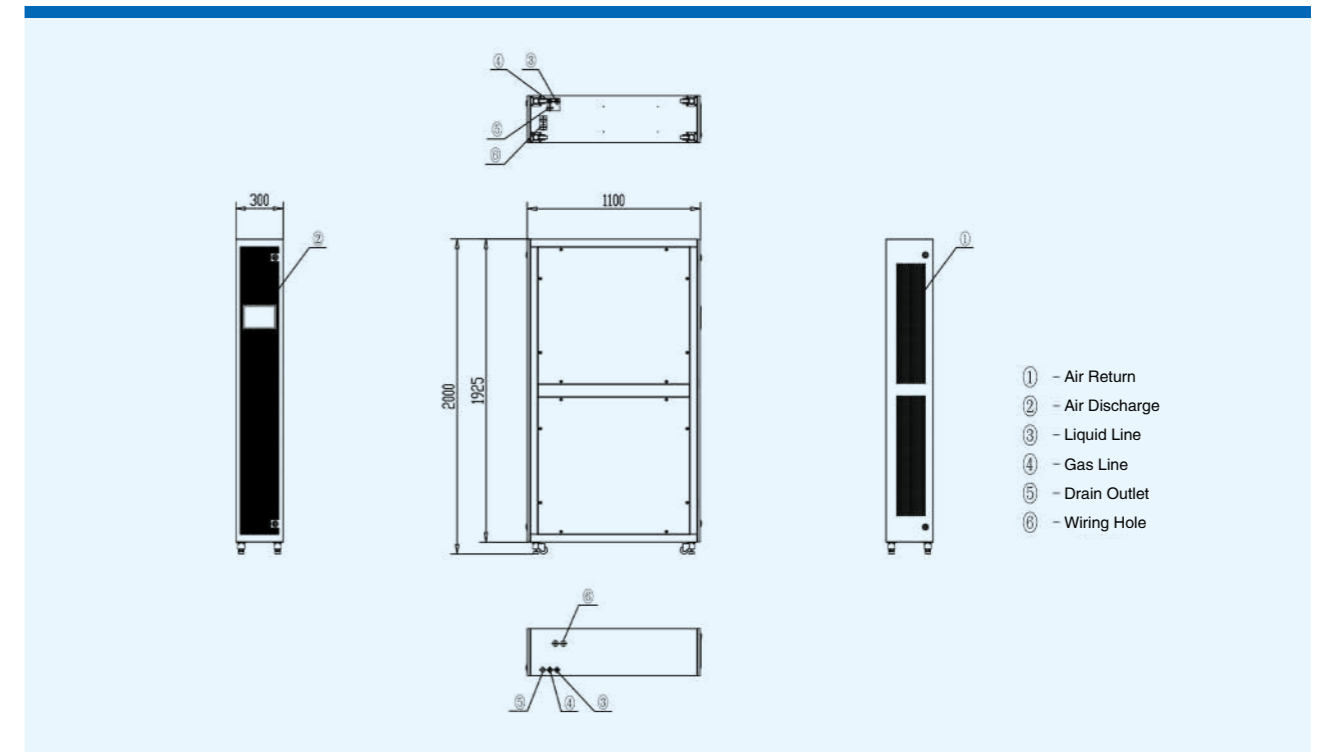

DXA38V1C2 Unit Dimension Drawing

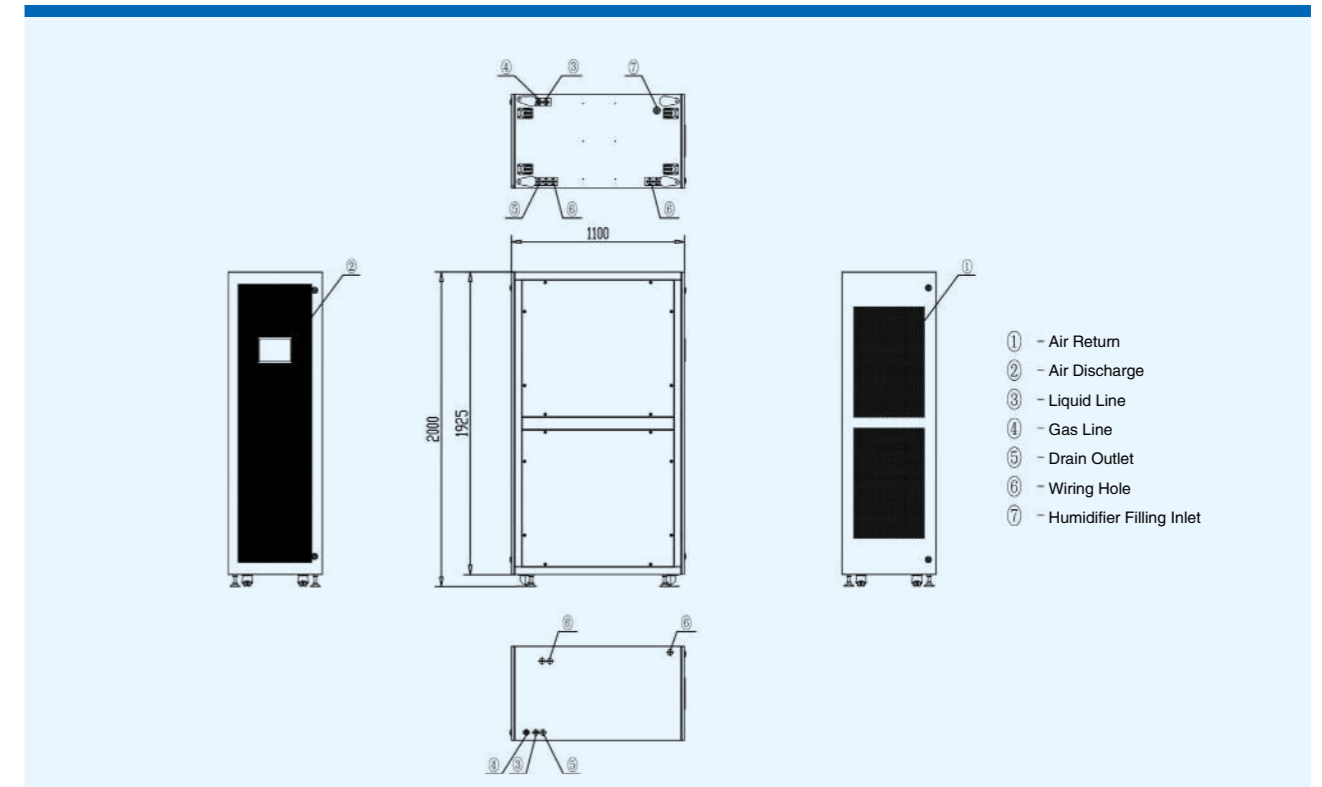

CW25C1 Unit Dimension Drawing

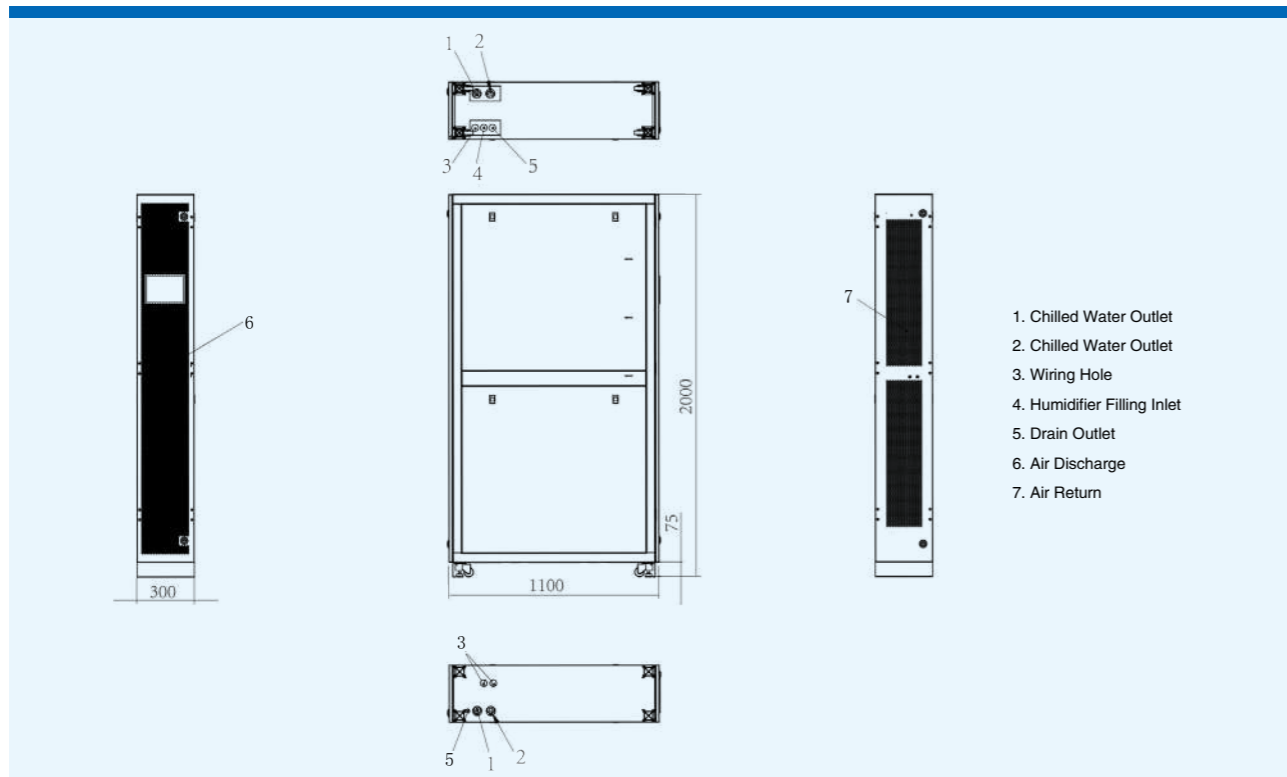

CMEG10V1 Condenser Dimension Drawing

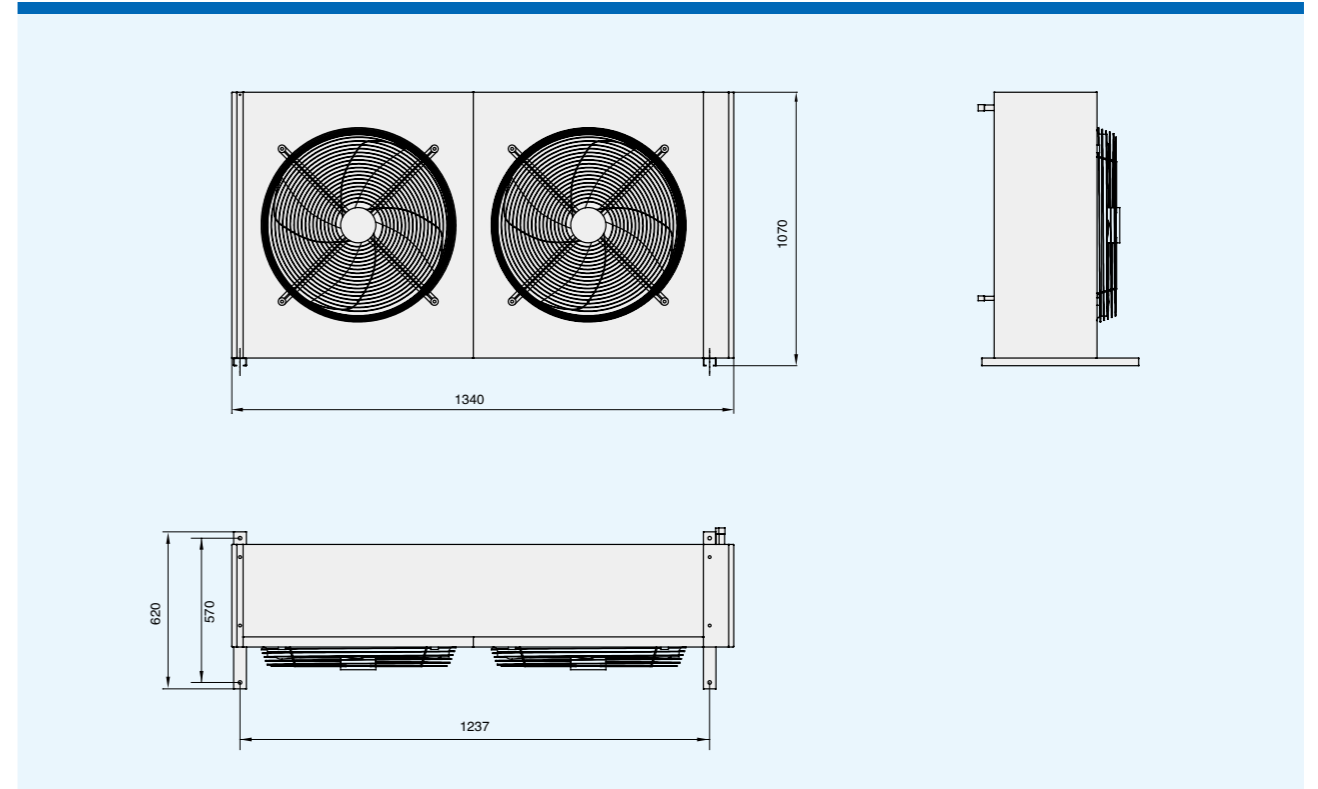

CW65C2 Unit Dimension Drawing

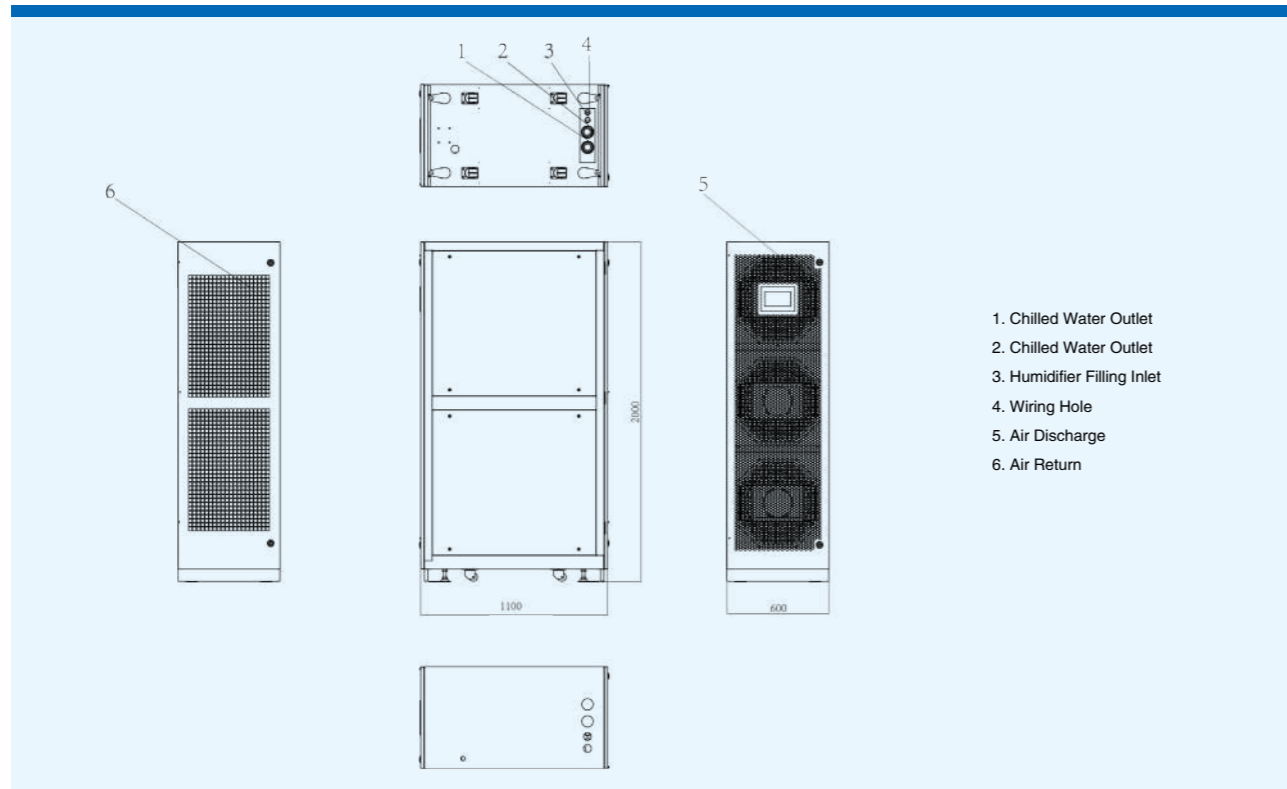

CMEG15/20V2 Condenser Dimension Drawing

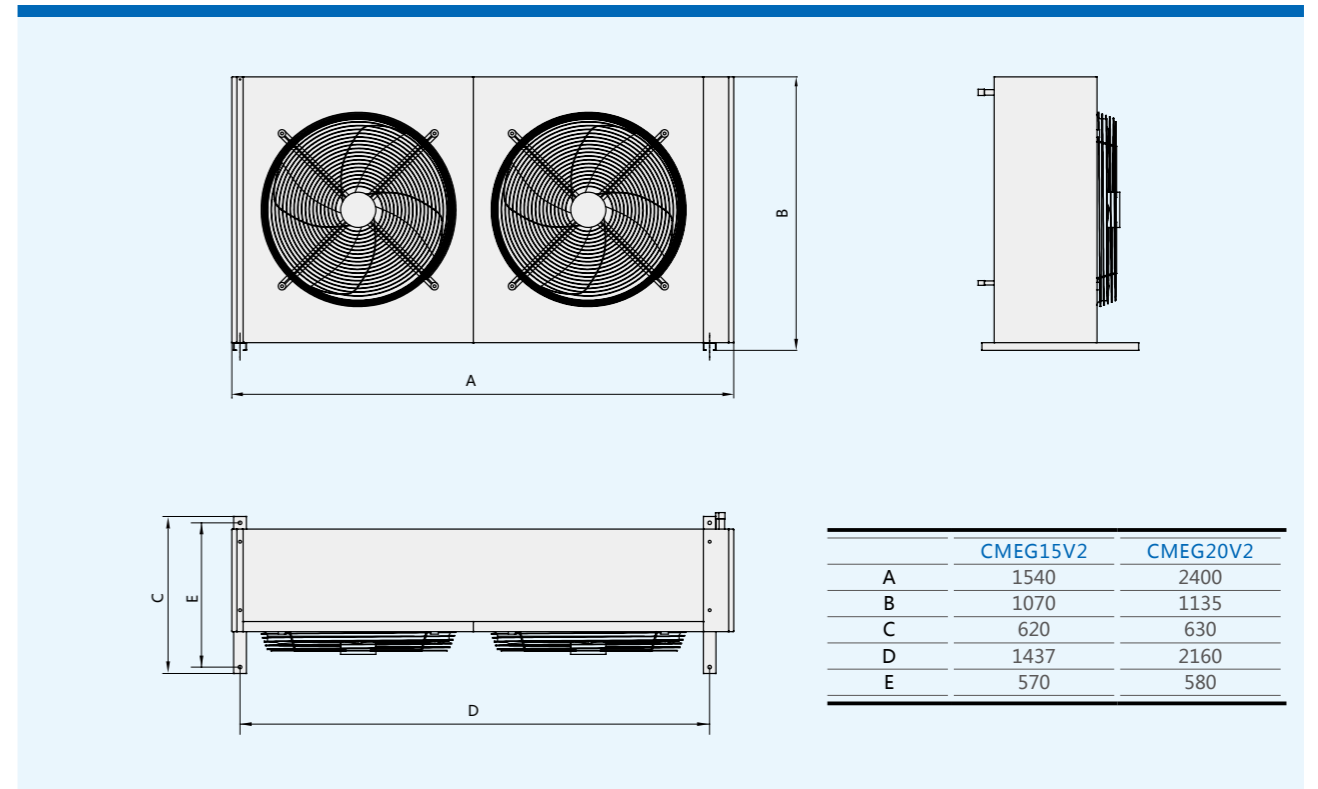



AIRSYS

Balance the Environment

AIRSYS is a cooling product and solution provider for ICT (Information & Communication Technology) industry.

The products include:

- Air conditioner and Chiller for IT room and large data center
- Intelligent Control system (BAS) for IT room and data center
- Air conditioning equipments for telecom shelters
- Intelligent control system for shelter cooling.
- Air conditioner and heat exchanger for telecom cabinets.

The solution include:

- Cooling system design
- System integration
- Installation and Commissioning
- Operation and Maintenance

AIRSYS is also a global leader in providing cooling solution for Medical Imaging System.

Airsys Refrigeration Engineering Technology (Beijing) Co., Ltd.

Add: 10th floor, Hongkun Shengtong building, 19, Ping Guo Yuan Xi Xiao Jie, Shijingshan, Beijing, China 100043
Tel: +86(0)10 68656161

Gu'an Airsys Environment Technology Company Ltd.

Add: 25, Dongfang Street, Gu'an Industry Park, Langfang City, Hebei Province, China
Tel: +86(0)10 68656161

Shanghai Airserve HVAC System Service Co., Ltd.

Add: #7-2, No.658, Daduhe Rd., Putuo District, Shanghai, China, 200333
Tel: +86(0)21 62452626 Fax: +86 (0)21 62459622

AIRSYS Australia Sales Office

Add: PO BOX 1088, Flagstaff Hill, SA, 5159, Australia
Tel: +61 479151080

AIRSYS BRASIL LTDA.

Add: Av. Moaci, 395 Conj 35/36 04083-000 – Planalto Paulista SAO PAULO – SP
Tel: +55 (11) 25976817 / +55 (11) 21585560

AIRSYS Deutschland GmbH

Add: Dahlweg 120, D-48153 Münster Germany
Tel: +49 (0) 1757535054 Fax:+49 (0) 251-97307479

AIRSYS Klima Sanayi ve Ticaret A.Ş.

Add: Barbaros Mah. Evren Cad. Erzurumlular Sk. No:23 Ataşehir / Istanbul Turkey
Tel: +90(216) 4706280 Fax: +90(216) 4706290

AIRSYS North America, LLC

ICT Cooling:

Add: 915 De La Vina St. Santa Barbara, CA 93101, USA
Tel: +1 (805) 312 7563 Call Centre: +1 (855) 874 5380

Medical Cooling:

Add: 3127 Independence Dr Livermore, CA 94551, USA
Tel: +1 800 7131543

AIRSYS Singapore Pte. Ltd

Add: 12 Lorong Bakar Batu #06-01 Singapore (348745)
Tel: +65 62787188 Fax: +65 68416301

AIRSYS (UK) Ltd.

Add: 245 Europa Boulevard, Warrington, UK. WA5 7TN
Tel: +44 (0) 1925 377 272 Call Centre: +44(0)8456099950

www.air-sys.com

Product design and specification subject to change without prior notice.